

Savair™ SDD200H

Pneumatically Operated Demand Drain

The Savair™ SDD200H pneumatically powered and controlled drain automatically collects and discharges condensate in compressed air applications. The drain saves energy because it expels no compressed air when it cycles, and it uses no electricity. The SDD200H is virtually maintenance-free and can handle up to 80% oil/water mixtures - without clogging!

SDD200H Operation and Design

The SDD200H is actuated by dry compressed air with typical service pressure of 80 – 130 psig. A unique air valve design delivers a positive OPEN and CLOSE force that prevents air loss when condensate is discharged. A ball valve support mechanism eliminates side-loading to prevent premature valve seal failure. Additionally, the valve port is large to aid the discharge of particulate. The drain cycles only when a predetermined amount of condensate has accumulated in a translucent reservoir. A stainless steel float rises with the level of condensate and initiates the discharge cycle. Condensate can be piped to enter the drain through either a top or bottom port. This versatile design eliminates the requirement for a vent line when the top port is used. Control air, used to operate the drain, is isolated from the compressed air that is in the reservoir while a test button is provided to confirm that the control air supply is operational.

The SDD200H has a horizontal profile that is advantageous for use in installations with limited clearance below the vessel to be drained. The design also eliminates “funneling” and keeps debris from accumulating in the discharge port.



SDD200H Performance Advantages:

- **Pneumatic Operation** – requires no electricity
- **No Air Loss** – eliminates energy waste
- **Large Capacity** – discharges 24 ounces per cycle
- **Large Discharge Port** – ½” full-port ball valve will not clog
- **Low, Horizontal Profile** – fits low-clearance applications
- **Requires No Vent Line** – simplifies installation
- **Positive OPEN/CLOSE Action** – will not leak
- **No Strainer Required** – reduced maintenance requirement
- **Non-Corrosive Construction** – long service life

The Savair™ SDD200H drain automatically discharges condensate with no loss of compressed air, and without clogging.

Savair™ SDD200H

Pneumatically Operated
Demand Drain

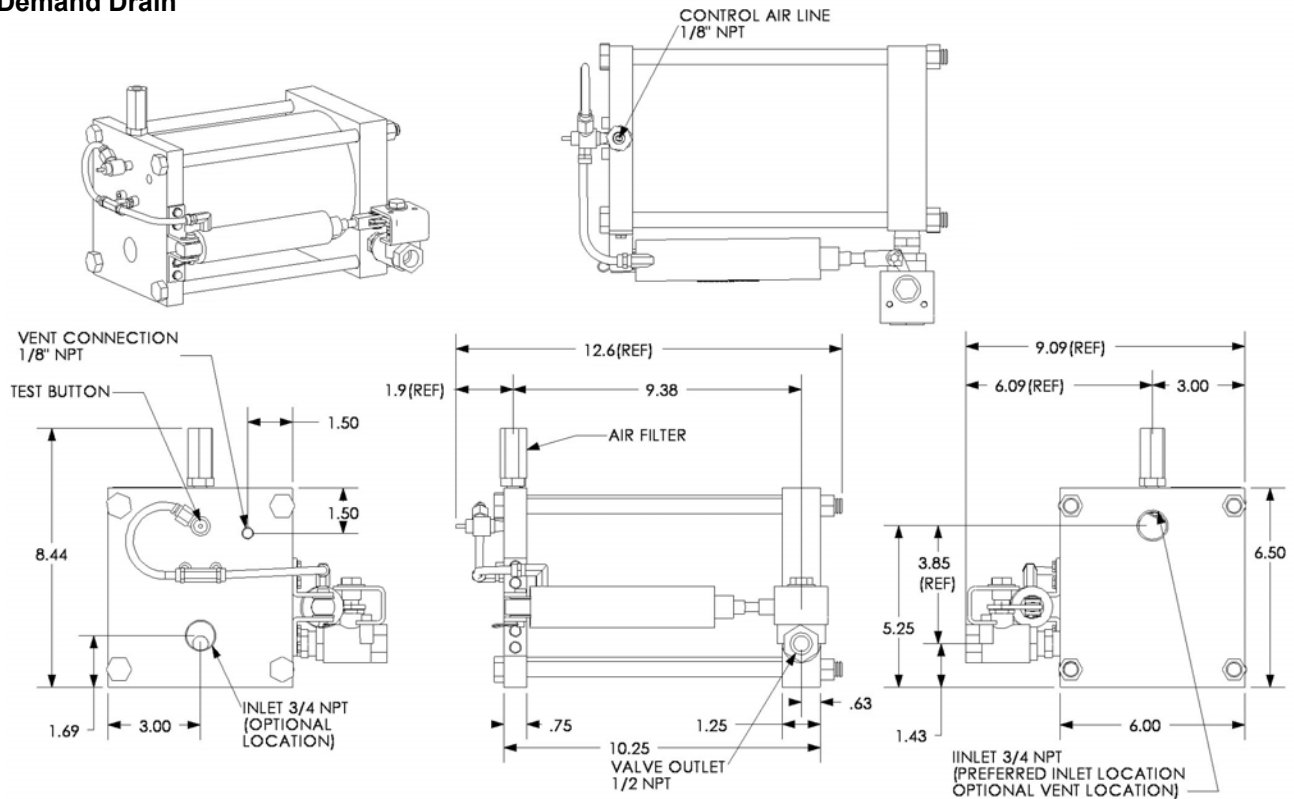

Technical Specifications

- Model: SDD200H
- Inlets: (2) 3/4" NPT and 1/2" NPT
- Outlet: 1/2" NPT
- Power: Clean, dry compressed air 80-130 psi
- Housing Pressure: 0-200 psi
- Operating Temperature: 32° F – 180° F
- Weight: 16 lbs.
- Discharge: 24 ounces per cycle
- Normal position: closed
- Construction Materials:
 - Reservoir: Aluminum and composite
 - Valve: Bronze with stainless steel ball and stem
 - Float: Stainless steel
 - Seat: Stainless steel
 - Seal: Viton



Specifications, illustrative materials and descriptions contained herein were as accurate as known at the time this publication was approved for reproduction. The company reserves the right to change specifications, discontinue models, equipment or design without notice and without incurring obligation. The information set out in this brochure is for preliminary information only and is not intended to constitute any representation or warranty by ZEKS to potential customers or to form the basis of a contract with any customer.



INNOVATIVE COMPRESSED AIR SOLUTIONS
www.zeks.com

1302 Goshen Parkway
West Chester, PA 19380
Phone: 610-692-9100 Fax: 610-692-9192 Web: www.zeks.com