

**Discharge all types of air system condensate
with no loss of compressed air**

Enterprise[™]

Zero Air Loss Condensate Drain

The Enterprise[™] Zero Air Loss Drain from ZEKs uses ultrasonic sensing technology to continuously measure the presence of condensate – ensuring no loss of compressed air. Constant monitoring of condensate volume within the drain, at a rate of 50 times per second, results in the fast and effective discharge of up to 60 gallons of condensate per hour. The Enterprise[™] operates well with clean, heavily emulsified, and dirty condensate.

The Enterprise[™] Drain's top and side condensate inlet ports afford installation flexibility for a variety of installations. When installed using the top inlet port in accordance with the installation instructions, the drain will provide no air loss draining without the need for a dedicated balance line. Installation using the side inlet port permits the drain to adapt to existing drain piping configurations for retrofit applications.

The Enterprise[™] includes features that address the realities of even the best compressed air systems. The large orifice of the direct acting valve minimizes the chances of drain blockage from typical compressed air contaminants, such as rust, scale or other debris. The drain also includes an automatic reset feature, which protects the electronic components of the drain from voltage peaks and other electrical supply irregularities.

The Enterprise[™] operates in a pressure range from 0 – 230 psi. The large condensate removal capacity makes it suitable for compressed air system component capacities of up to 3000 scfm. Kits are available to make service a simple operation – in the field or in the shop.



Enterprise[™] ***Drain Advantages:***

- ***Does not vent compressed air to atmosphere***
- ***Large internal orifices will not clog***
- ***High condensate volume removal capacity***
- ***Effective for all condensate types***
- ***Compact size fits tight applications***
- ***Corrosion resistant design***

Enterprize™

Zero Air Loss Condensate Drain

Two models are available:

NCC1701-D for 115 volt installations

NCC1702-D for 230 volt installations

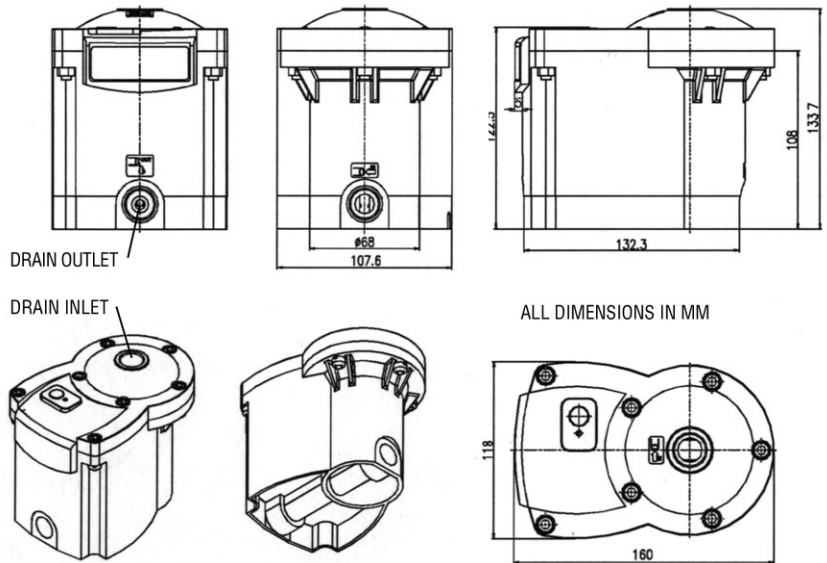

Technical Specifications

Condensate Inlet Connections: ½" NPT (top & side)

Condensate Discharge Outlet Connections: ½" NPT

Min./Max. Pressure: 0 – 230 psi

Min./Max. Temperature: 35°F - 140°F

Electrical Connection: 115 VAC or 230 VAC; 50/60Hz

Valve: 1/2 direct-operating with FPM seals, large orifice

Electrical Protection/Rating: IP65/NEMA 4

Controls: One push button for TEST

Indicators: One LED showing operational status

Operation: 50 volume checks per second

Y-Strainer included: for protection and easy clean out

Weight: 3 lbs.

Warranty: 1 year

Service and Maintenance kits are available for Enterprize™ drains.

Reference the part numbers below when ordering:

#683672 Service Kit - Plunger assembly, Plunger O-ring, Springs

#683673 Maintenance Kit – Service kit plus Housing seal, Cleaning brush, Allen wrench

Specifications, illustrative materials and descriptions contained herein were as accurate as known at the time this publication was approved for reproduction. The company reserves the right to change specifications, discontinue models, equipment or design without notice and without incurring obligation. The information set out in this brochure is for preliminary information only and is not intended to constitute any representation or warranty by ZEKS to potential customers or to form the basis of a contract with any customer.



1302 Goshen Parkway
West Chester, PA 19380
Phone: 610-692-9100 Fax: 610-692-9192 Web: www.zeks.com

INNOVATIVE COMPRESSED AIR SOLUTIONS
www.zeks.com